



OPERATION AND INSTALLATION MANUAL

PROVOZNÍ A INSTALAČNÍ PŘÍRUČKA

Document number:

EA-2386

(ATA 61-20-86)

HYDRAULICAL CONSTANT SPEED GOVERNOR FOR M-601 ENGINES

Hydraulický regulátor konstantních otáček pro motory M-601

Governor Model

P-94()-()

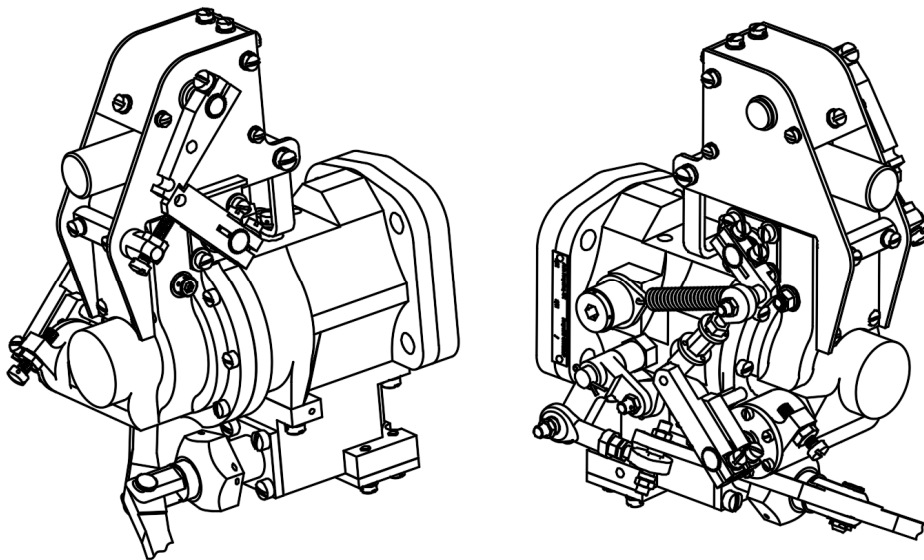

Issue 1: October 11, 2021

Revision: -

1. Vydání: 11.října, 2021

Revize: -

The technical content of this document is approved under authority of DOA No. EASA.21J.072.

Technický obsah tohoto dokumentu je schválen na základě oprávnění DOA č. EASA.21J.072.

WARNING

People who fly should recognize that various types of risks are involved; and they should take all precautions to minimize them, since they can not be eliminated entirely. The governor is a vital component of the aircraft. A mechanical failure could cause a forced landing.

Governors are subject to constant vibration stresses from the engine.

Before a governor is certified as being safe to operate on an airplane engine, an adequate margin of safety must be demonstrated. Even though every precaution is taken in the design and manufacture of a governor, history has revealed rare instances of failures, particularly of the fatigue type.

It is essential that the governor be properly maintained according to the recommended service procedures and a close watch be exercised to detect impending problems before they become serious. Unusual operation characteristics should be investigated and repaired as it could be a warning that something serious is wrong.

The governor is among the most reliable components of your airplane. It therefore deserves the care and maintenance called for in this Manual. Please give it your attention, especially the section dealing with Inspections and Checks.

Thank you for choosing Avia Propeller governor. Properly maintained it will give you many years of reliable service.

Your Avia Propeller technical support team

TABLE OF CONTENTS	Page
Table of Contents	I-1
List of Revisions	II-1
List of Effective Pages	III-1
1. General	1-1
2. Model Designation	2-1
3. Performance Data	3-1
4. Design and Operation Information	4-1
5. Installation and Operation Instruction	5-1
6. Inspections	6-1
7. Trouble Shooting	7-1
8. Shipping and Storage	8-1
9. Governor Installation Record	9-1
10. Warranty Registration Card	10-1

LIST OF REVISIONS

Revision No.		Date of Issue	Revised Pages	Remark
-	-	2021-10-11	All	Initial Issue

LIST OF EFFECTIVE PAGES

Page	Date
Cover	2021-10-11
I-1	2021-10-11
II-1	2021-10-11
III-1	2021-10-11
1-1	2021-10-11
2-1	2021-10-11
3-1	2021-10-11
3-2	2021-10-11
4-1	2021-10-11
4-2	2021-10-11
4-3	2021-10-11
4-4	2021-10-11
5-1	2021-10-11
5-2	2021-10-11
5-3	2021-10-11
5-4	2021-10-11
5-5	2021-10-11
5-6	2021-10-11
5-7	2021-10-11
5-8	2021-10-11
6-1	2021-10-11
7-1	2021-10-11
7-2	2021-10-11
8-1	2021-10-11
9-1	2021-10-11
10-1	2021-10-11

1.0 GENERAL

The P-94()-() hydraulic propeller governors are dual acting governors developed for hydraulically variable pitch propellers with feathering and reversing capabilities, optional pitch lock and synchrophasing, produced by AVIA Propeller.

1.0.1 Statement of purpose

This publication provides operation, installation and line maintenance information for the Avia Propeller P-94()series governors.

Installation, removal, operation and trouble shooting data is included in this publication. However, the airplane manufacturer's manuals and applicable propeller manuals should be used in addition to this information.

1.1 DEFINITION OF COMPONENT LIFE AND SERVICE

1.1.1 Overhaul

Overhaul is a periodic process and contains the following items:

- disassembly
- inspection of parts
- reconditioning of parts
- reassembly

The overhaul interval is based on hours of service (operating time) or on calendar time.

At such specified periods, the governors should be completely disassembled and inspected for cracks, wear, corrosion and other unusual or abnormal conditions.

As specified, certain parts should be refinished, and certain other parts should be replaced.

For overhaul interval for the governors please refer to Service Bulletin No.1 at www.aviapropeller.cz

1.1.2 Repair

Repair is correction of minor damage caused during normal operation. It is done on an irregular basis, as required.

A repair does not include an overhaul.

Amount, degree and extent of damage determines whether or not a governor can be repaired without overhaul.

1.1.3 Component Life

Component life is expressed in terms of total hours of service (TT, or Total Time) and in terms of hours of service since overhaul (TSO, or Time Since Overhaul).

Both references are necessary in defining the life of the component. Occasionally a part may be "life limited", which means that it must be replaced after a specified period of use.

Overhaul returns the component or assembly to zero hours TSO (Time Since Overhaul), but not to zero hours TT (Total Time).

No life limit is established for P-9() series governors.

2.0 MODEL DESIGNATION

P - 9 4 0 - 1

1 2 3 4 5

- 1 P = Propeller Governor
- 2 9 = Manufactured by AVIA Propeller, reversing
- 3 4 = Dual acting, for M-601 engines

- 4 = Special arrangements
 - 0 = feathering, mechanical control
 - 1 = 0 + speed sensor
 - 2 = 0 + pitch lock
 - 3 = 0 + synchrophasing coil
 - 4 = 0 + speed sensor + pitch lock
 - 5 = 0 + pitch lock + synchrophasing
- 5 = Application Number, Settings of Control Lever and Relief Valve Pressure etc.

S/No. 21 G 003 A

a b c d

- a** = Year of Manufacture (2021,)
- b** = Governor
- c** = Consecutive Number
- d** = Modification

3.0 PERFORMANCE DATA

Range of acceptable operation temperature from -20°C (-4.4°F) to +150°C (+302°F).

The governor uses engine oil with a pressure at the inlet channel between 15 psi and 125 psi (1,02 bar and 8,50 bar).

The torque required at 220 psi and 2700 rpm is 1 Nm (8 inch lbs).

3.1 Dimensions

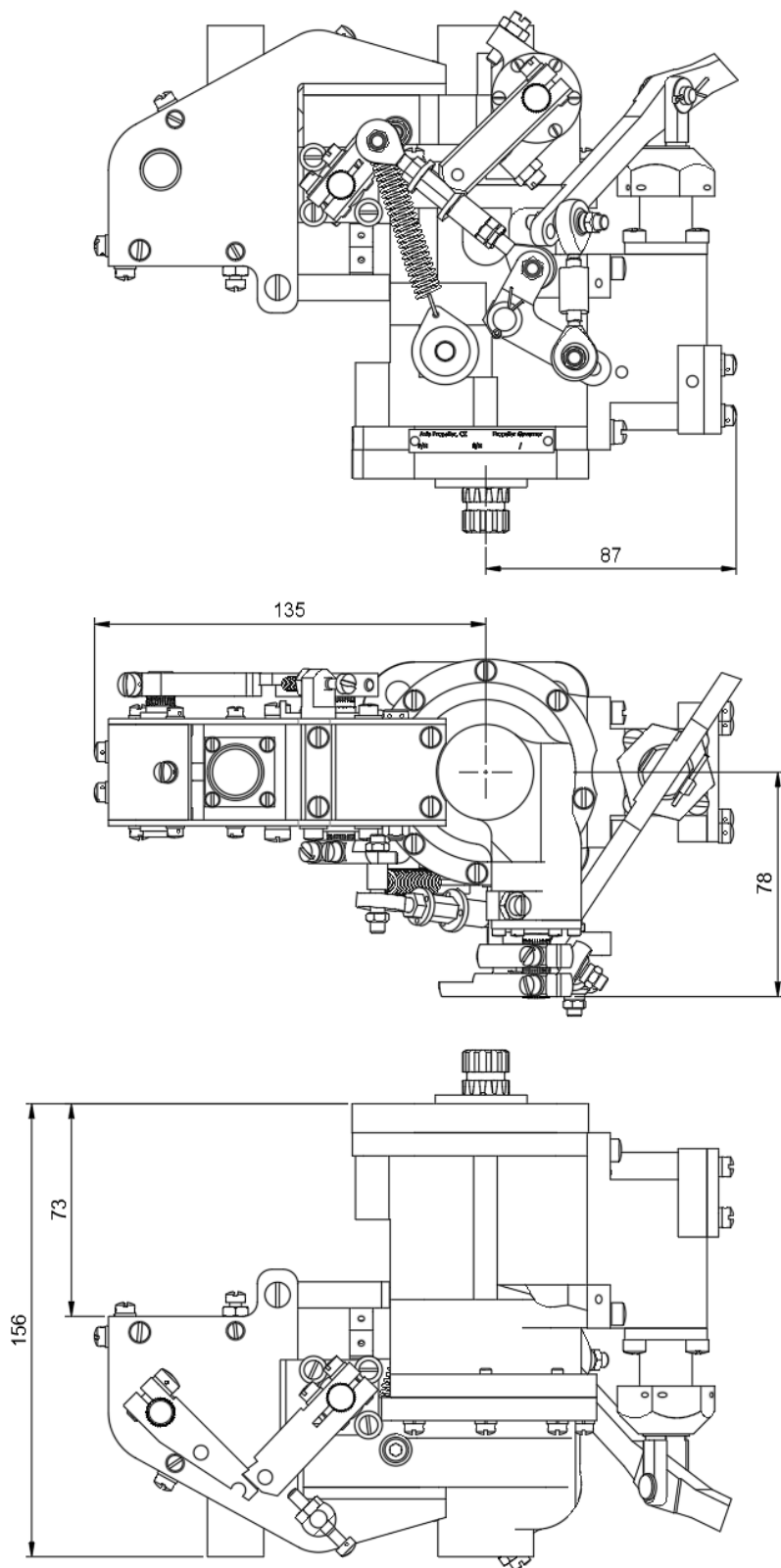

Weight =2,4 kg (4,65 lbs) in basic configuration

4.0 DESIGN AND OPERATION INFORMATION

The **Avia Propeller** aircraft governors **P-94()-()** are base mounted centrifugal governors for use with hydraulic constant speed propellers on turboprop engine aircraft.

They regulate propeller speed by continually varying the pitch of the propeller blade to match propeller torque (and, hence, engine load) to engine developed torque as changes occur in flight conditions. The governors are single-acting or dual-acting, using oil pressure to decrease pitch. Pitch change in the opposite direction is accomplished by the force of the propeller blade counterweights twisting moment and servo spring plus hydraulic pressure in dual-acting configuration at overspeed condition.

The principal parts of each governor are a gear-type oil pump with pressure relief valve, flyweights pivoted on a rotating flyweight head, a spring-loaded pilot valve positioned by the flyweights, an external control lever that varies the spring load on the pilot valve, and beta valve to control blade pitch in beta mode of operation.

The body, cover and base are made of aluminum. The body contains the necessary passages to channel oil to the propeller pitch changing mechanism, and the base is designed to fit the standard AND20010 engine pad.

The governor can be equipped with optional pitch lock valve, which prevents propeller going into uncommanded reverse by closing control port. The valve is solenoid actuated and the solenoid is activated when propeller is reaching beta switch activation set point without movement engine control lever into beta mode of operation.

The sensing element of the governor is a set of pivoted flyweights mounted on a rotating flyweight head and linked mechanically to the engine gears, through a hollow drive gear shaft.

The flyweights, actuated by the centrifugal force developed by the speed of the rotation, position a pilot valve so as to cover or uncover ports in the drive gear shaft and control the flow of oil to and from the pitch changing mechanism of the propeller. The centrifugal force exerted by the flyweights is opposed by the force of an adjustable speeder spring. The load exerted by the speeder spring determines the engine rpm required to develop sufficient centrifugal force in the flyweights to center the pilot valve. Oil to operate the propeller's pitch changing mechanism is supplied by a gear-type oil pump at a pressure value limited by a relief valve.

There are four conditions of the governor in operation - on-speed, overspeed, underspeed, and beta control. Description and diagrams below in this chapter.

4.1 ON-SPEED:

In this condition the forces action on the engine-governor-propeller combination are in a state of balance. The speed adjusting control lever has been set by the pilot to obtain the desired engine rpm. The propeller blades are at the correct pitch to absorb the power developed by the engine. The centrifugal force of the rotating flyweights exactly balances the force of the speeder spring. The pilot valve is located in the drive-gear shaft, so that the control ports between the oil pump and the propeller pitch changing servo are covered. Pressure oil from the gear pump is circulated through open governor relief valve back to the inlet side of the pump.

4.2 OVERSPEED:

This condition occurs when airspeed or horsepower is increased and engine rpm increases above the onspeed value - set by the speed adjusting control lever. The rotating flyweights pivot outward as their increase centrifugal force overcomes force exerted by the speeder spring.

The flyweight toes raise the pilot valve plunger, uncovering ports in the driver gear shaft that permit pressure oil to flow from the propeller pitch changing mechanism. For dual-acting control system, the valve opens also high pitch channel for pressurized oil. This allows propeller counterweights and pressurized oil in dual-acting systems to take the propeller blades toward a higher pitch. The load on the engine is increased and engine speed is reduced.

This, in turn, reduces centrifugal force exerted by the flyweights in opposition to the force of the speeder spring. The flyweights return to an on-speed position and the pilot valve plunger covers ports in the driver gear shaft, blocking flow of pressure oil to or from the pitch changing mechanism of the propeller – return to on-speed condition.

4.3 UNDERSPEED:

An underspeed condition occurs when the airspeed or horsepower is decreased and engine rpm falls below the rate established by the setting of the speed adjusting control lever. The decrease in the centrifugal force of the rotating flyweights causes them to pivot inward under the force exerted by the speeder spring.

The pilot valve plunger is forced down uncovering the ports in the drive gear shaft that allow pressure oil to flow to the pitch changing mechanism or the propeller.

This overcomes the force of the propeller counterweights and decreases the pitch of propeller blade.

This reduces the load on the engine, thereby increasing engine speed and the centrifugal force developed by the rotating flyweights. The flyweight toes lift the pilot valve plunger to cover the control ports. At this point the forces acting on the engine-governor-propeller combination are again balanced and the engine is back to the on-speed setting.

NOTE:

LOSS OF OIL FROM THE PROPELLER PITCH CHANGING MECHANISM DUE TO ENGINE TRANSFER RING LEAKAGE WILL RESULT IN CHANGED SPEED SETTINGS.

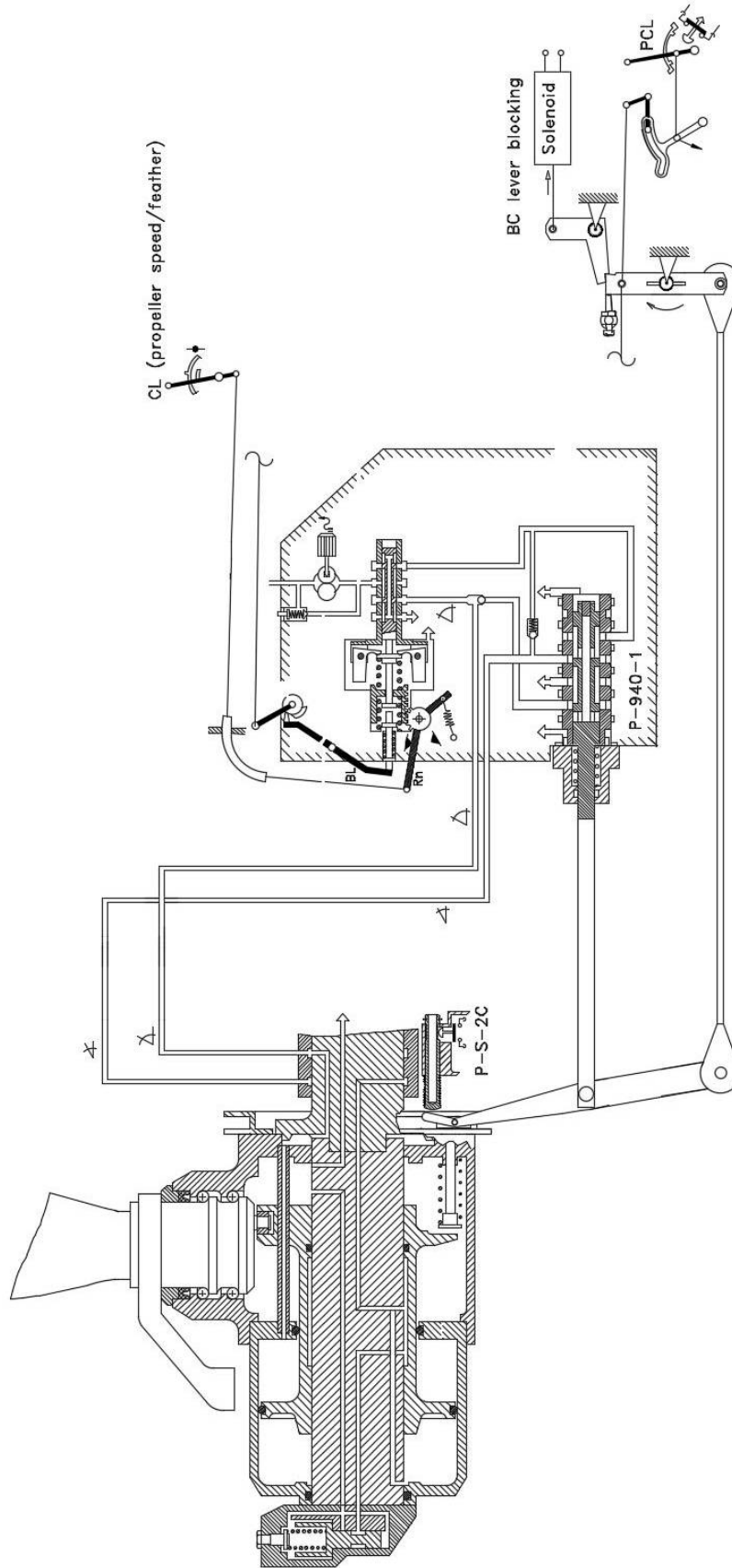

Dual Acting Control System in On-speed Condition

Pilot Valve – Dual Acting

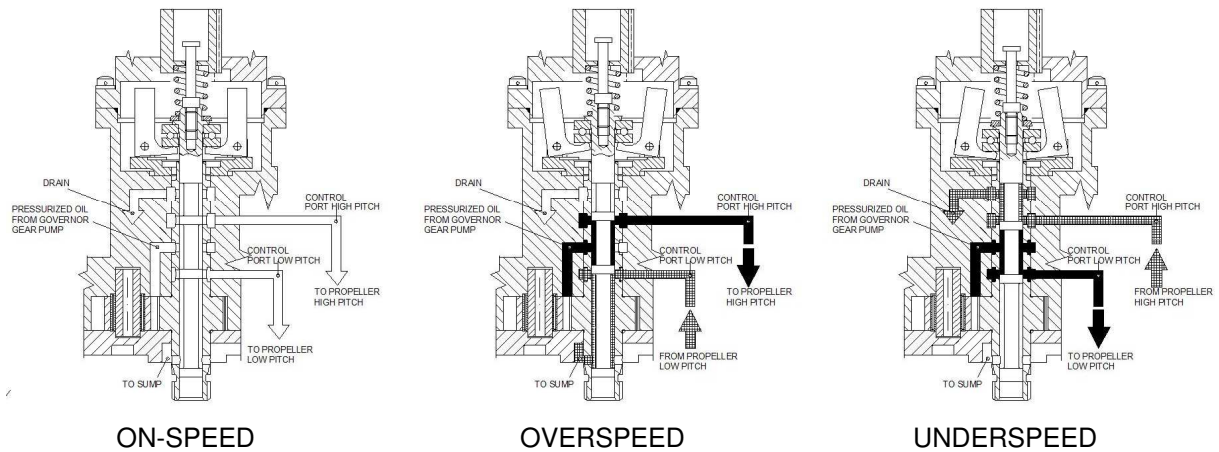

Constant Speed Mode of Operation

4.4 Beta control

Beta control mode of operation is intended for ground operation only to use engine power for braking the plane after landing. Reversing is controlled with engine Power Control Lever (PCL), by moving the lever backward behind idle stop.

Beta control starts from minimum pitch, where the propeller is locked by beta valve. The beta slide valve is positioned by feedback lever, which is connected by one side with control linkage and the other side with beta ring. Movement of the engine control lever into beta range also moves feedback lever such a way, that the beta slide valve is moved out of the beta valve. It means that the control port is again open and the pressurized oil can flow again into the propeller and turn the blades toward lower pitch.

Beta range is indicated by beta switch, which is located on the bottom of engine gear box.

The governor is equipped with active beta control blocking. PCL (see the complete diagram) has to be equipped with beta enable switch. Activation of the switch will deactivate BC lever blocking, which allows to put PCL in BETA range. It is not possible to use beta/reverse range without it. The switch provides voltage to the solenoid, which releases BC lever of the governor. BC lever movement provides propeller beta control. As soon as the control enters into beta range, it is not necessary to keep the solenoid energized. After setting the forward mode of operation again, BC lever is automatically re-locked. The picture below shows how the blocking works.

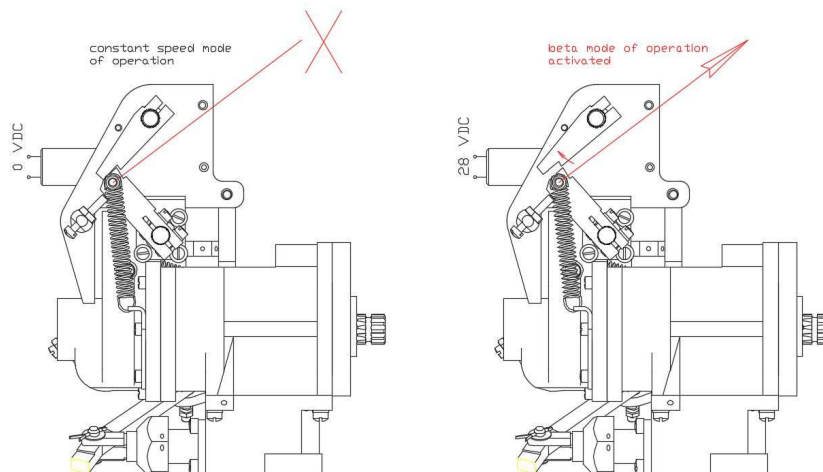

5.0 INSTALLATION AND OPERATION INSTRUCTION

5.1 Propeller Governor Installation

- a) If applicable: Remove old governor per aircraft service instructions or procedure in this manual.
- b) Prepare new mounting gasket, **P/N 222-0163**. **Coat gasket with engine oil or equivalent before installation.**

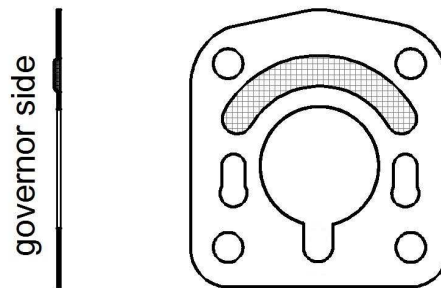

Gasket P/N 222-0163

- c) Clean engine pad, studs and mounting hardware before installing new mounting gasket. Insure governor drive spline mate correctly with engine accessory drive spline. Place the governor to its position.
- d) Attach mounting hardware and torque 4 mounting screws to 20-24 Nm (180-220 inlbs).
- e) Reconnect push-pull control to outermost hole on governor control lever and adjust linkage per aircraft service information – also see chapter 5.5.

NOTE: The speed control lever (RN) can be adopted for push-pull control linkage by positioning on spline shaft end. Simply remove the “long” adjustable lever from the shaft, place in requested position and lockwire again.

CAUTION: Mechanical lock between FEATHER and BETA prevents moving the BETA lever (BC) to beta mode of operation when the speed control lever is in feather position and vice versa it prevents the speed control lever to feather position when the BETA lever is in beta mode of operation. **ALLWAYS** keep the speed control lever (RN) in maximum speed position when manipulating with BETA lever! **ALLWAYS** keep the beta control lever (BC) at stop screw when manipulating with RN lever!

ATTENTION: To move with BC lever, disconnect BETA feedback lever from the connecting rod, see picture.

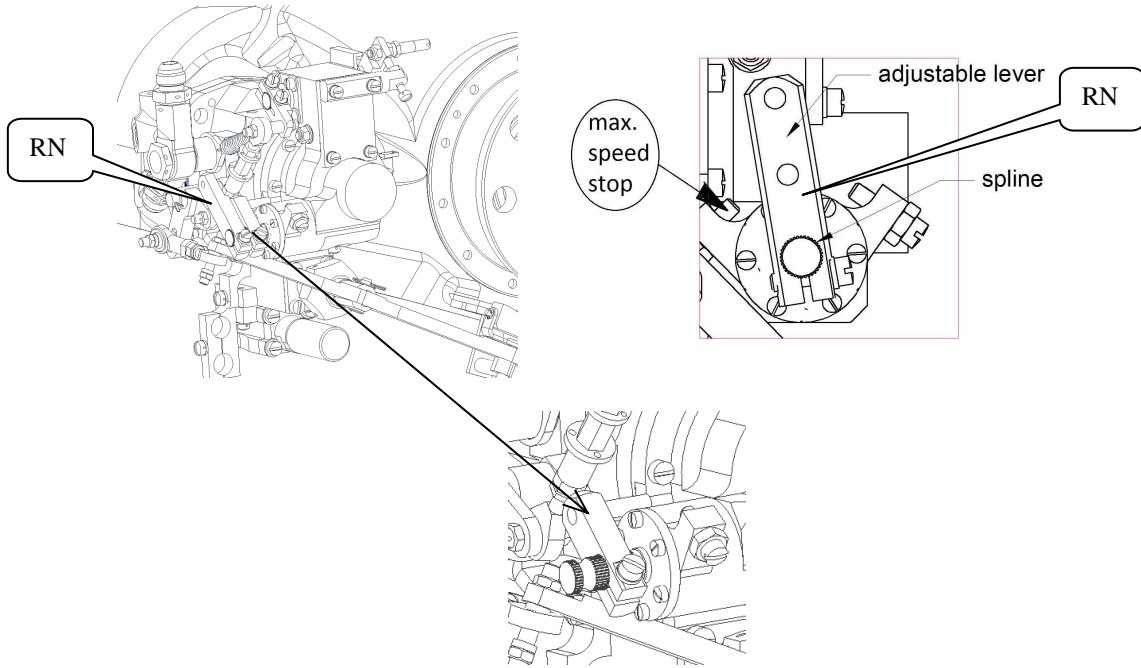

Detail after RN lever removing

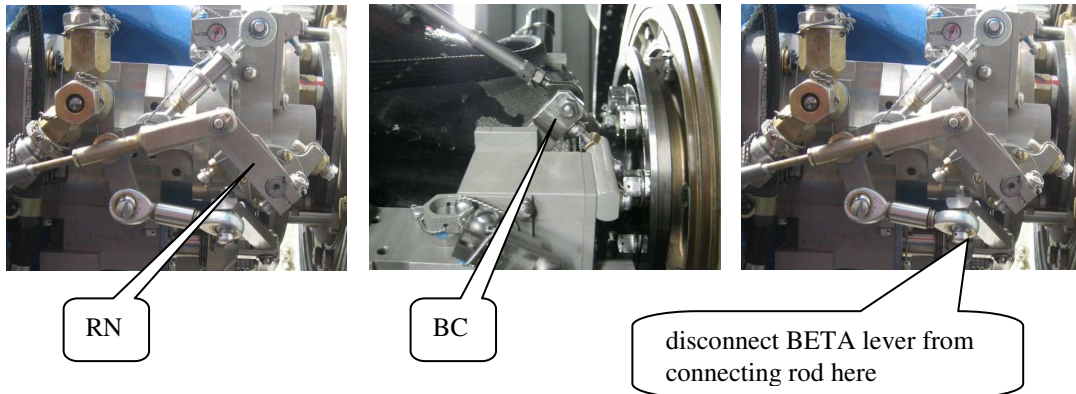

5.2 Beta Lever Support and Beta Switch Installation

- a) Install the beta lever support together with beta switch—see picture below.

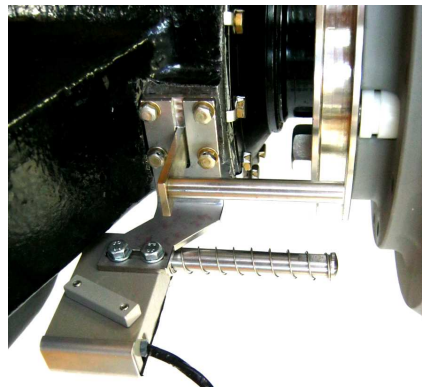

Dual acting P/N 222-0161-6 (with P-S-2C Beta Switch)

- b) Secure installation hardware.

5.3 Carbon Block Installation / Exchange

- a) Check the clearance between the carbon block and the beta ring. Refer to appropriate Propeller Operation and Installation Manual for required clearance.
- b) Release the feedback lever from the connecting rod.
- c) Release and remove feedback lever pivoting pin and remove the feedback lever.
- d) Install carbon block assembly on the feedback lever and into the beta ring. Move the feedback lever with carbon block toward the beta ring and measure the clearance between the feedback lever and the support pin. Use the shims to establish the clearance **1,2 to 1,5 mm** between the feedback lever and the support pin.
- e) Install the pivoting pin, secure with a cotter pin.
- f) Connect the feedback lever with the connecting rod.

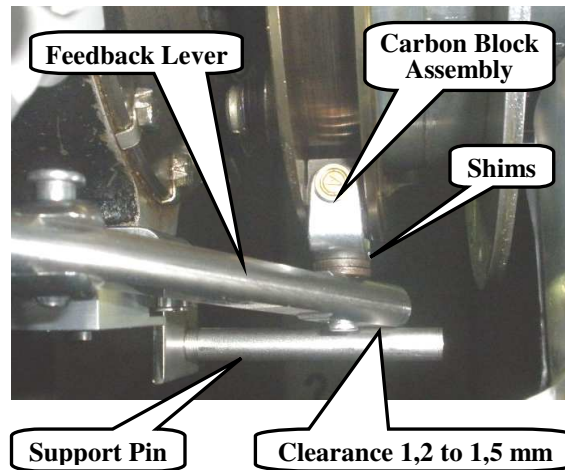

5.4 Minimum Flight Angle (MFA) Setting

This setting ensures basic functionality of the control system

- a) If applicable, install a propeller.
- b) Propeller beta ring has to be fully protruded for single-acting system or intruded for dual-acting system.
- c) Install a carbon block and secure with supporting assembly.
- d) Adjust beta valve position such a way, that the face of the beta valve cover matches with recess in the fork.

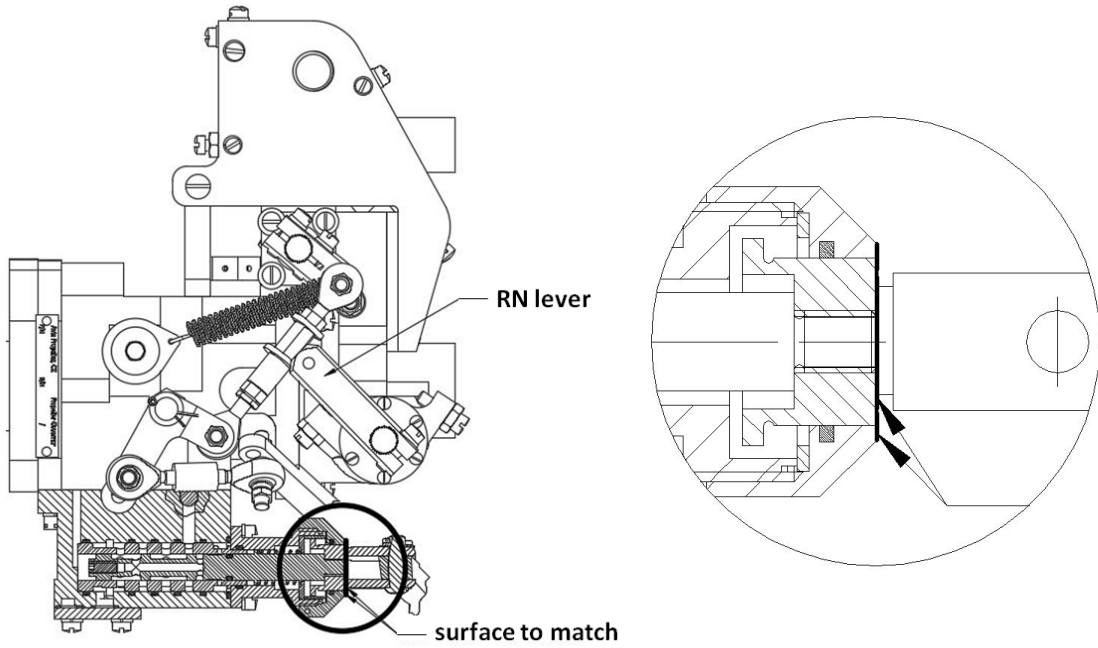

e) Lockwire the adjusting element.

CAUTION: Mechanical lock between FEATHER and BETA prevents moving the BETA lever (BC) to beta mode of operation when the speed control lever is in feather position and vice versa it prevents the speed control lever to feather position when the BETA lever is in beta mode of operation. **ALWAYS** keep the speed control lever (RN) in maximum speed position when manipulating with BETA lever!!!

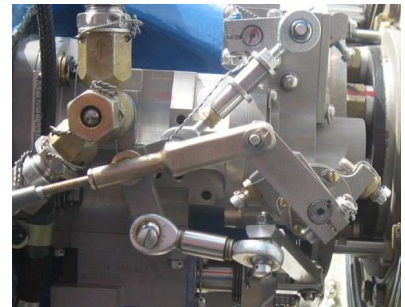

ATTENTION: Adjusting element has left and right thread, left thread nut is lockwired. **USE** correct wire orientation for left thread.

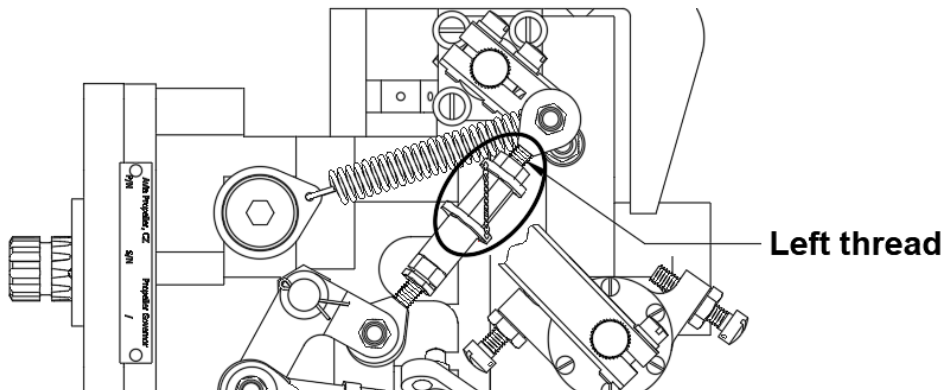

5.5 P-S-2C Beta Switch Adjustment

The P-S-2C beta switch is to be adjusted by using gauge blocks inserted between beta switch cam and beta lever.

- a) The propeller must be in feather position and BC lever is touching end stop.

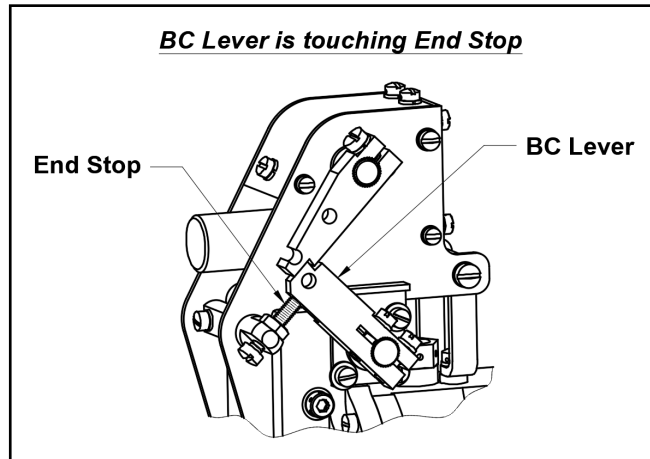

- b) Disconnect beta switch connector.
- c) The beta switch is fixed on the bracket with two screws which are screwed through the housing and secured with self-locking nuts. To allow positioning the beta switch on the bracket:
 - 1) Loosen (not remove) two self-locking nuts.
 - 2) Loosen (not remove) the screws.

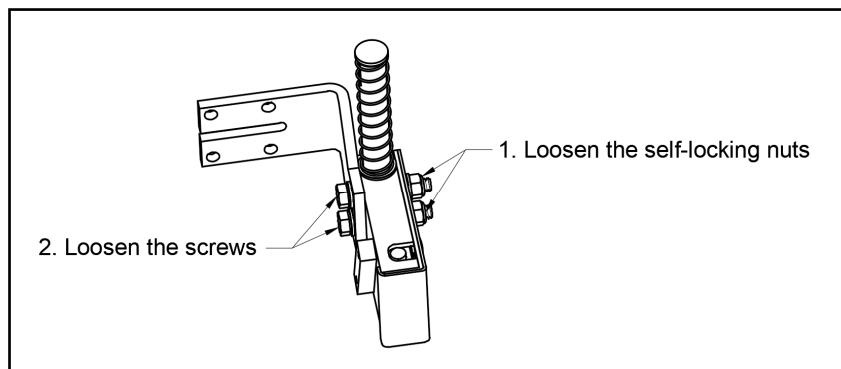

- d) Connect beta switch contact indicator P/N 300-488 or use pins “A” and “B” to measure ON/OFF position.
- e) Use adjusting fixture P/N 900-0545 or gauge block between the cam and beta feedback lever.
 - 1) When OFF side of the fixture or 10,5 mm gauge block is inserted between the cam and beta feedback lever, the switch must be OFF.

- 2) When ON side of the fixture or 11,3 mm gauge block is inserted between the cam and beta feedback lever, the switch must be ON.

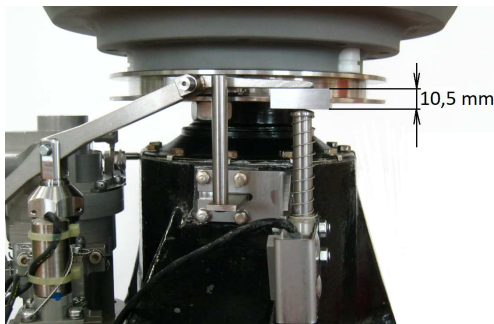

Beta switch P-S-2C is OFF

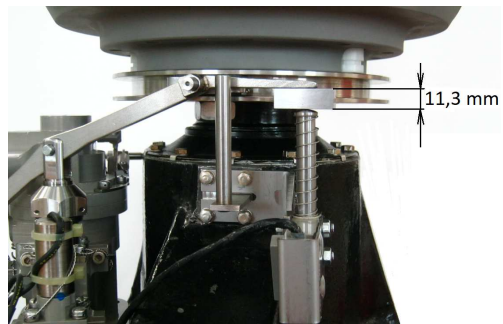

Beta switch P-S-2C is ON

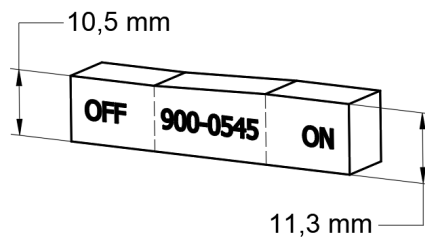

Fixture P/N 900-0545

- f) After adjustment, tighten the screws to fix the beta switch on the bracket and secure the screws with self-locking nuts. When tightening the nut, hold the screw head from turning.
- g) Re-connect the connector.

5.6 ACTIVE BETA RANGE BLOCKING CONTROL

Connect beta blocking mechanism solenoid with suitable “beta enable” switch (24 VDC, 2A) on PCL in cockpit. As soon as the switch is closed, it energized solenoid and the solenoid turns with blocking lever, enabling to use beta range of the propeller control. Once the PCL is moved in beta range, it is not necessary to keep the solenoid energized.

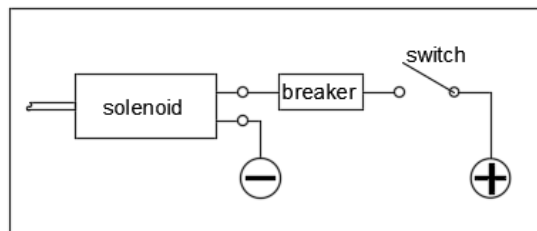

When the PCL is moved back to flight position and the switch is de-energized, BC lever blocking mechanism is set to position, where it mechanically blocks BC lever against movement to beta range.

Recommended mating connector for the solenoid:
MS3476W8-98S (+ strain releaser M85049/52-1-8W)

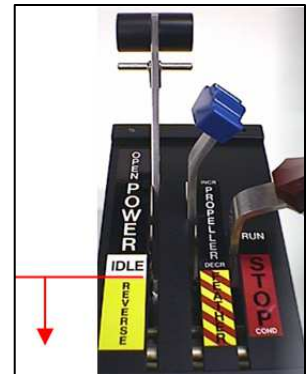

5.7. Maximum Propeller Speed Adjustment

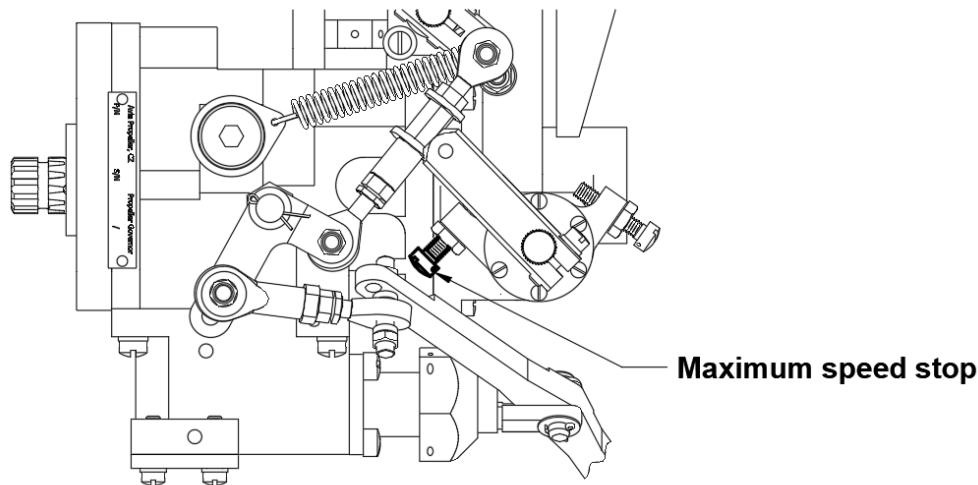

NOTE: It is possible to set maximum rpm with the described procedure only in a limited range. This is a normal maintenance procedure and fully authorized.

When it is found during static run or flight check it is necessary to adjust maximum speed, follow this procedure.

- a) Remove lock wire from the stop screw and loose the lock nut of the screw.
- b) Set maximal propeller's RPM by turning the stop screw. One quarter turn clockwise will reduce RPM by approximately 25 RPM. One quarter turn counterclockwise will increase RPM by approximately 25 RPM.
- c) Lock the stop screw at maximal RPM stop and torque the nut with 2.5 Nm (22 in. Lbs).
- d) Lockwire the stop screw at maximal RPM stop with safety wire.

5.8 Static Run-up :

ATTENTION: PERFORM THE STATIC RUN UP ON A CLEAN AREA , DO NOT DAMAGE THE PROPELLER BLADES DUE TO STONES ETC.

Lock aircraft brakes. Start the engine. Place cockpit propeller RPM lever in MAX RPM position.

PULL BACK THE PROPELLER LEVER 3 TO 5 TIMES TO SPILL THE SYSTEM AND REMOVE THE AIR IN THE SYSTEM.

Advance throttle lever slowly to maximum permitted engine power. Record propeller RPM. As a general rule, propeller could be 25-100 RPM below the red line limit during check.

Record propeller speed at idle.

Check beta range up to maximum reverse. **DO NOT EXCEED 1980 PROPELLER RPM.**

Immediately after engine stop, check the governor for oil leakage.

Make a record in engine/governor log book.

5.9 Flight Test

Tests should be done in smooth air. During takeoff acceleration, record maximum propeller RPM. When sufficient altitude is reached, level out aircraft, leaving propeller control in MAX RPM position. Maintain this setting for 3 to 5 minutes while monitoring propeller RPM. Following this check, two conditions may exist which require adjustment:

- a) If the propeller RPM is exceeding the redline limit, reduce it to the redline using propeller control. Leaving propeller at this redline RPM setting, land aircraft and shutdown. Remove cowling and note position of control arm and governor. Adjust governor high RPM screw (see chapter 5.6) clockwise so it just touches stop on governor control arm; this will ensure that the correct arm position for governor redline RPM setting cannot be exceeded.
- b) If the propeller is below red line limit with max RPM setting on the propeller cockpit control, note RPM and land. Remove engine cowling and adjust the governor high RPM screw stop (see chapter 5.6) counterclockwise to increase of approximately 25 RPM.
- c) Perform another flight to confirm the adjustment was sufficient.

5.10 Governor Removal

- a) Remove carbon block supporting assembly.
- b) Remove push-pull linkage in accordance with aircraft service instructions.
- c) Remove mounting nuts and washers.
- d) Tap on the governor to release it if necessary and then remove governor from engine pad.
- e) Governor drive and engine pad must be without impurities (metal chips etc.). If it is necessary, clean governor drive and engine pad by appropriate means.
- f) Apply the gasket and transport cover to governor base.
- g) Record the removal in engine/governor logbook.
- h) Perform preservation in accordance with section 8.0 to prepare for long- term storage.

6.0 INSPECTIONS

Check for oil leakage.

Check oil leakage immediately after engine stop.

Check oil leakage at governor's surface and at mounting pad.

If oil leakage is detected, check stop nuts at the governor housing and the mounting nuts.

Torque if necessary. If oil leakage is detected repeatedly contact service center or governor's manufacturer.

WARNING: NO OIL LEAKAGE IS PERMITTED.

7.0 TROUBLE SHOOTING

Propeller Surging or "Wandering" - Possible Causes:

7.1 EXCESSIVE TRANSFER BEARING LEAKAGE

Engines with excessive transfer bearing leakage can experience surging since the governor may not be able to get enough pressure to the propeller. This causes a delay in propeller responsiveness and by the time the propeller responds to earlier governor inputs, they have changed, resulting in propeller "wandering".

Solution: Perform a transfer bearing leakage test per engine manufacturer's instructions. If test indicates a high rate of leakage (even though it may still be on the high side of "acceptable" tolerance), this maybe your cause. Install the suspect governor on a known "good" aircraft, if problem disappears, engine work may be indicated.

7.2 MALFUNCTIONING FUEL CONTROL UNIT

Unstable fuel control unit could arise feeling, that propeller control is unstable. Be sure, that fuel control unit is stable.

7.3 DIRTY ENGINE OIL

Contaminants in dirty engine oil can cause blockage of close tolerance passages in governor, leading to erratic operation.

Solution: Timely engine oil changes should eliminate this problem.

7.4 EXCESSIVE "PLAY" IN AIRCRAFT PROPELLER CONTROL LINKAGE

Excessive "play" in the linkage between the governor and the cockpit control often leads to erratic operation. Specifically, if the propeller RPM is suddenly changing and holding a new setting on its own, this could indicate loose linkage.

Solution: Trace linkage and locate unsecured sections and tighten-up as needed. Please note that although linkage may appear to allow full governor control while the engine is off, it may not in the air. Engine vibration and "stretch" of the mount during operation can often aggravate the condition. Therefore, it is important the entire length of linkage be properly secured, even if the ends alone are tight.

7.5 EXCESSIVE PROPELLER FRICTION

NOTE: This is rarely the cause of RPM malfunction.

Propeller may be overly-resistant to pitch movement. This can be caused by either excessively tight shimming of the propeller blades, or internal corrosion or part failure, causing binding.

Solution: Check amount of blade "play" as defined below:

A total lack of blade "shake" may indicate excessively tight blade shims. If this is suspected, have the propeller checked by a qualified EASA/FAA-approved propeller repairman. Note that this check and any needed correction can usually be performed with the propeller installed on the aircraft.

7.6 PROPELLER MOVES SLOWLY FROM FEATHER POSITION

When unfeathering the propeller at turboprop engine, the propeller is unfeathered in 8-10 s. It is a standard reaction of the control system and propeller, as the propeller turns slowly in feather and governor hydraulic pump capacity is proportional to propeller speed.

As soon as unfeathering time is increasing in operation, especially comparing with the other propeller, it could be a symptom of relief valve pressure reduction (this pressure reduction has a negative effect to pump capacity at low speed).

Solution: If the tendency of unfeathering time is increasing, replace the propeller governor.

8.0 SHIPPING AND STORAGE

Conservation

Inner conservation is automatically done by engine oil. Attach cover cap.

After installing the governor the conservation is done together with engine in accordance with the instruction of the engine manufacturer.

Outside conservation isn't required.

Pack the governor in two layers of wax-cloth and put it in a plastic bag. The plastic bag should be vacuumed and after that welded.

Make a note in the governor's logbook.

Deconservation isn't needed.

Storage

Governors have to be packed in carton box with accessory documentation.

Store governors in temperature from +10°C (+50°F) to +30°C (+86 °F) and relative humidity from 40 % to 80 %. Keep stock room free of gases with deleterious effect.

9.0 GOVERNOR INSTALLATION RECORD

P/N:

S/N:

Note:

Date installed	Notes	Authorized Signature	Date Removed

Warranty Registration Card

- 1) To be eligible for warranty, this registration card must be returned completed and signed by the end user to the authorized Avia Propeller distributor of the area in which the governor is firstly operated or to Avia Propeller itself within 30 days after date from starting operation.
- 2) No other warranties and/or guarantees than defined in the actual warranty conditions are made.
- 3) Governor Type:

P	-	9	4		-			
---	---	---	---	--	---	--	--	--

S/N:

		G			
--	--	---	--	--	--

Date of purchase (day/month/year): ___/___/_____

Date of De-conservation (day/month/year): ___/___/_____

Owner's name:

Company:

Address:.....

City/State/Postal code

Country:

Telephone:..... Telefax:.....

E-mail:

Sold by:

I have read and understood the Operator’s Manual in its entirety and will observe the instructions therein.

Date: Signature: